



**Low-pressure  
solutions**

# KAESER Blowers

## Rotary Lobe and Rotary Screw Blowers

Flow rate 0.6 to 160 m<sup>3</sup>/min

Pressure differential: Gauge pressure up to 1100 mbar, Vacuum up to 550 mbar

## Magnetic Bearing Turbo Blowers

Flow rate up to 267 m<sup>3</sup>/min, Pressure differential 0.3 to 1.3 bar

# KAESER blowers

## The world-renowned compressor and blower manufacturer

Established by Carl Kaeser Sr as a machine workshop in 1919, KAESER started on the road to becoming one of the world's leading compressed air systems providers when the first reciprocating compressor left the Coburg production line in 1948. The final breakthrough came in the early 1970s with the development of the rotary screw compressor featuring the energy-saving SIGMA PROFILE.



## Gera plant

In 1991, KAESER acquired the “Geraer Kompressorenwerke”, a company with a proud heritage forged over more than 100 years of compressor and blower manufacture. Production of KAESER’s newly developed OMEGA rotary lobe blowers began at the plant in Thuringia in 1993 and today these highly efficient systems are exported, together with all necessary accessories and equipment, to every

corner of the globe. Covering an area of over 60,000 m<sup>2</sup>, the Gera facility currently employs approximately 300 people producing KAESER’s extensive range of rotary lobe blowers, rotary screw blowers and compressed air refrigeration dryers. All companies in the international KAESER group are linked by the very latest information and network technology.

# Contents

How a KAESER rotary lobe blower works .....	04
How a KAESER rotary screw blower works .....	05
Rotary screw blowers with the SIGMA PROFILE .....	06-07
CBS – HBS series, SFC/STC version – Dependable and efficient.....	08-09
Rotary lobe blowers with the OMEGA PROFILE.....	10-11
BBC – FBC series, OFC/STC version: Optimised complete blower systems .....	12-13
SIGMA CONTROL 2 blower controller .....	14-15
Rotary lobe blower packages: BBC–HBC series.....	16-17
Premium blowers: HB – PI series.....	18-19
Magnetic bearing turbo blowers .....	20-21
Complete solutions from a renowned systems provider .....	22-23
Accessories .....	24-25
Special versions .....	26-27
Advanced manufacture.....	28-29
Technical specifications.....	30-31

## Fields of application

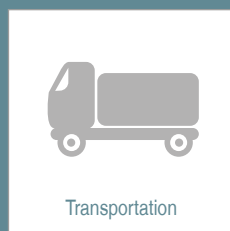

Efficient and oil-free gas transportation, pneumatic conveying of bulk materials, drinking and wastewater treatment (filter cleaning and clarification tank aeration), liquid homogenisation and forced air systems for combustion equipment; the possibilities are almost endless – KAESER blowers are as versatile and varied as the applications for which they are used.

# How a KAESER rotary lobe blower works

The pressure build-up process – the images show a cross-sectional view through the flow chamber of the KAESER OMEGA rotary lobe blower block.

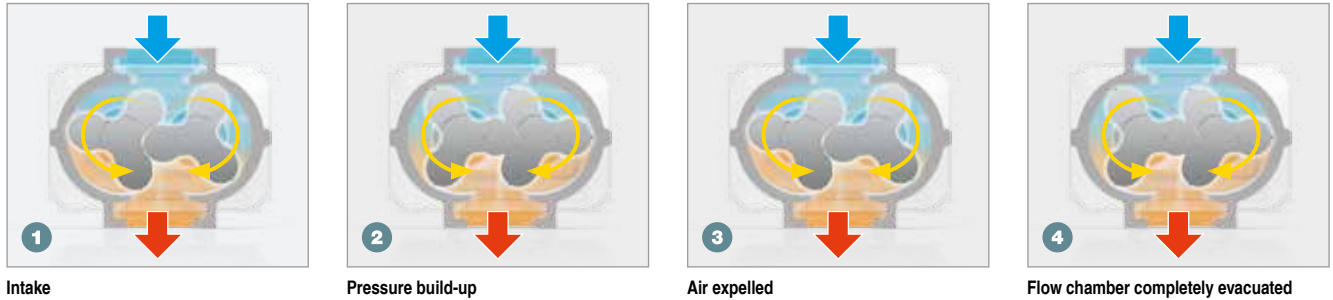

## Oil-free, isochoric compression process

As the intake air passes through the flow chamber inside the rotary lobe blower, its volume remains constant (isochoric process).

Actual compression takes place outside the blower block, with the accumulation of the air mass taking place during the subsequent process.

This “adaptive” compression always produces only as much pressure as is needed by the process in question. This makes rotary lobe blowers particularly well suited to applications where they spend a relatively high proportion of their time at Idle (such as pneumatic conveying) and/or applications with heavily fluctuating pressure.

The numbers correspond to the points in the pressure-volume diagram.

- 1) Intake and capture of atmospheric air (left rotor).
- 2) Air is conveyed towards the pressure side; pressure increase commences at the 120° angle of rotation due to the prior influx of air that has already been compressed.
- 3) Compression in the flow chamber ceases; discharge commences.
- 4) Conveyed air mass is discharged into the process.

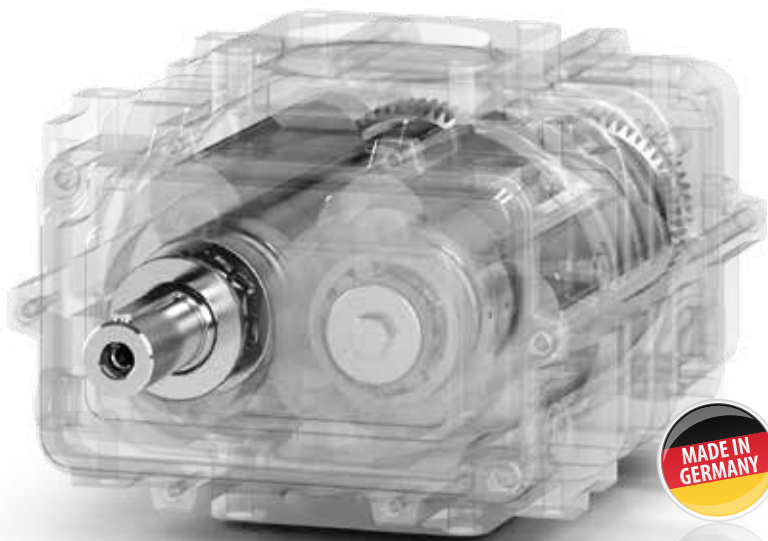
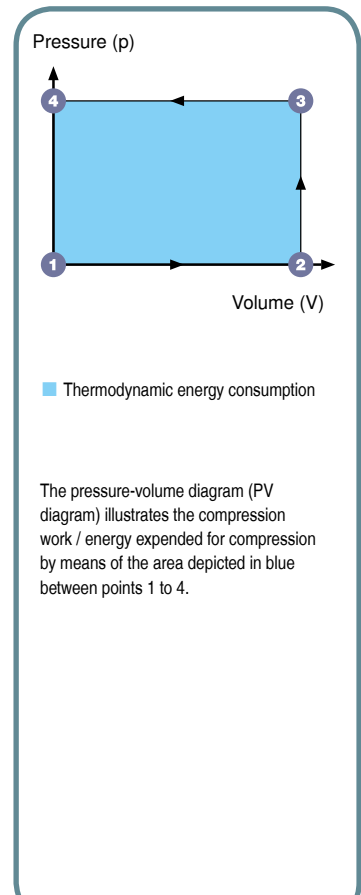

Image: OMEGA block



The pressure-volume diagram (PV diagram) illustrates the compression work / energy expended for compression by means of the area depicted in blue between points 1 to 4.

# How a KAESER rotary screw blower works

The pressure build-up process – the images show cross-sectional views of the enclosed air volume within the KAESER SIGMA-B rotary screw blower airend, seen from the pressure side of the rotor pair.



1 Intake air is captured



2 Volume is reduced



3 Expelled to pressure side



4 Flow chamber completely evacuated

## Oil-free, isentropic compression process

As the intake air passes through the flow chamber inside the rotary screw blower, its entropy remains largely constant (isentropic process).

Actual compression takes place inside the airend: the volume of air is continuously reduced until the moment of discharge and is pushed out under pressure – since less effort is required for compression of the same air volume, energy consumption is reduced. Rotary screw blowers are the ideal solution for applications with more or less constant pressure and high running performance require-

ments, such as clarification tank aeration at wastewater treatment plants, flotation, etc.

The numbers correspond to the points in the pressure-volume diagram.

- 1) Intake and capture of atmospheric air.
- 2) Air conveyed towards the pressure side for discharge.
- 3) Pressure increases due to volume reduction.
- 4) Compressed air is expelled.



Image: SIGMA blower airend

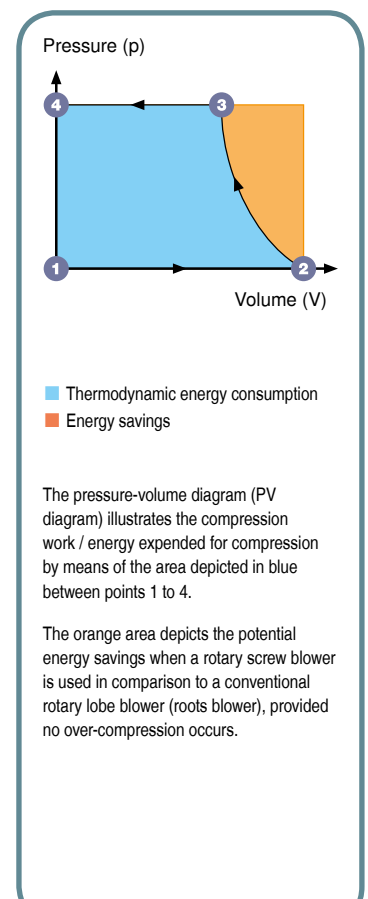



### **CBS, DBS and EBS drive concept**

In CBS, DBS and EBS series rotary screw blowers, power is transferred from the motor to the blower air end via integrated gearing. This has proven to be the best solution for the prevailing speeds in this performance and size class when it comes to efficiency, reliability and durability.



### **FBS belt drive – refined to perfection**

The pivoting motor base with tensioning spring ensures precision belt tensioning, irrespective of motor weight, thereby providing optimum levels of transmission efficiency at all times. As a result of the company's decades of experience in compressor design and engineering, this approach to power transmission has been refined to perfection.

# Rotary screw blowers – with the efficient SIGMA PROFILE

Developed at the company's in-house Research and Development Centre, KAESER rotary screw blower airends with their world-renowned SIGMA PROFILE rotors are up to 35% more efficient than conventional compressor designs.

They also benefit from a particularly broad control range and virtually constant specific package input power.

In addition to efficiency, durability was also an essential development objective. The use of high-tech bearings and the fact that no ancillary equipment is required serves to minimise energy consumption whilst also enhancing reliability.

## Technical specifications:

CBS, DBS, EBS, FBS, HBS series  
Usable flow rate:  
4.5 to 160 m<sup>3</sup>/min

Pressure differential:  
- Gauge pressure up to 1100 mbar  
- Vacuum up to 550 mbar



## Guaranteed performance specifications

To ensure that the projected savings are actually achieved during operation, KAESER quotes effective overall power consumption figures, as well as the usable flow rate, in accordance with the stringent tolerances of ISO 1217, Annexe C or E (as applicable).



## Dependable seals

Field-proven in KAESER rotary screw compressors, the sliding ring seal for the rotary transmission drive shaft lead-through on the blower airend is maintenance-free and provides a dependable sealing, even in hot and dusty environments.



## Durable bearings

Four heavy-duty roller bearings absorb 100% of the radial forces exerted on the cylinders, guaranteeing a long service life for the rotary screw airend. The rolling elements are encased in high-tech cages for optimum lubrication at all speeds. No additional oil pressure lubrication is required.

# Rotary screw blowers – CBS, DBS, EBS, FBS & HBS, SFC/STC version

KAESER rotary screw blowers are user-friendly turnkey systems, delivered ready for immediate operation. All that is needed is to connect them to a power supply and the air network; the laborious processes of oil-filling, drive belt installation, motor adjustment, procurement of a suitable frequency converter, programming, cabling in accordance with EMC regulations, drawing wiring diagrams, arranging CE and EMC-certification, etc. are thankfully consigned to the past.

Procuring complete, certified machines from systems manufacturers ultimately saves you both time and money, whilst guaranteeing many years of reliable operation.

**SFC version:** Variable speed with frequency converter

**STC version:** With Y-Δ-Starter



## SIGMA CONTROL 2 controller

The SIGMA CONTROL 2 ensures efficient blower control and system monitoring at all times. Numerous interfaces enable rapid communication with control centres via data bus, whilst the SD card slot ensures data storage and updates are a breeze. Various operating modes are selectable on SFC/OFC machines.



## Seamless system monitoring

Sensors for oil level and temperature monitoring are integrated into the blower airend. The oil chamber is designed to ensure dependable oil level measurement in all operating phases.





### Cool inlet air

Process air and cooling air for the motor are drawn in separately from outside the housing. This boosts efficiency and leads to a higher usable air mass flow rate for the same power consumption. The blowers can operate at full capacity in ambient temperatures up to +45 °C.



### Optimised specific package input power

The moderate maximum speed, an extra-dense screw profile and near constant specific package input power across a broad, variable-speed control range all combine to achieve significant energy savings across the entire operating curve.



### Durable OMEGA blower block

The OMEGA blower block delivers pressures up to 1000 mbar(g), block discharge temperatures up to 160 °C, a broad control range with speed-controlled operation, Q 2.5 rotor balancing for quieter operation, extended service life and minimal maintenance requirements.



### Durable bearings

Heavy-duty cylinder roller bearings absorb 100% of the continuously changing radial gas forces. As a result, they avoid the springing effect of self-aligning bearings and last up to ten times longer with the same load.



# Rotary lobe blowers – Air at the touch of a button

The special OMEGA Profile featured on KAESER's three-lobe rotary lobe blowers makes these machines true masters of energy efficiency. The long-term dependability and durability of these units are legendary.

These qualities can be attributed to design features such as the use of straight-cut timing gears, heavy-duty cylinder roller bearings and precisely balanced rotors.

## Technical specifications for the full, connection-ready version:

Usable flow rate:  
1.5 to 72 m<sup>3</sup>/min

Pressure differential:  
- Gauge pressure up to 1000 mbar  
- Vacuum up to 500 mbar



### Precision manufacture/synchronisation

KAESER blower blocks feature high-precision, 5f 21 quality straight-cut timing gears with minimal flank clearance, which play a major role in contributing to the block's outstanding volumetric efficiency. Since the straight-cut gearing is not subjected to continuously changing axial gas forces, heavy-duty cylinder roller bearings can be used.



### Stable rotors

An extremely high rotor balancing quality of Q 2.5, combined with the rotors' single-piece design including the shaft ends, ensures a vibration-free, low-noise operation. Rotor tips with integrated sealing strips make the blower block more resistant to dust particulates and thermal stress.

# Complete, turnkey rotary lobe blowers BBC-FBC series, OFC/STC version

KAESER's turnkey COMPACT series blowers with OMEGA PROFILE rotors provide more than just a dependable and energy-efficient performance.

Delivered ready for connection, complete with all sensors, star-delta starter (or frequency converter) and CE/EMC labelling, they significantly reduce the work and costs required for planning, installation, certification, documentation and commissioning.



## START CONTROL (STC)

The version with integrated Y- $\Delta$ -starter operates at a constant speed and is equipped with a premium contactor, overcurrent relay and phase sequence monitoring. A SIGMA CONTROL 2 controller and dependable emergency stop system complete the package.



## Variable speed control

With OMEGA FREQUENCY CONTROL (OFC), the frequency converter uses speed control in order to adjust the delivery volume of the blower to match the required air demand. Everything is delivered ready for immediate operation, since all programming and parametrisation is carried out at the factory.



## Plug-and-play

Turnkey blowers not only come complete with all necessary sensors, STC/OFC, SIGMA CONTROL 2 and emergency stop switch, but are also ready-filled with oil and fully certified. This significantly reduces the work and costs required for planning, installation, documentation and commissioning.



## EMC-tested and certified complete system

To ensure seamless integration into any operating environment, the electromagnetic compatibility (EMC) of all components and of the complete machine has been tested and certified in accordance with all applicable regulations.





Digital output device, e.g. laptop



Control centre

KAESER CONNECT



SIGMA AIR MANAGER 4.0

Communications module (e.g. Modbus TCP)



## KAESER SIGMA NETWORK



Controller:  
SIGMA CONTROL 2

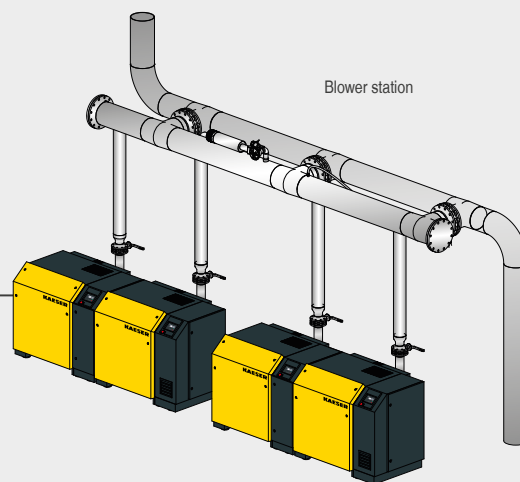

Blower station



### Industrie 4.0 – Join the network

With the SIGMA CONTROL 2 blower controller and SIGMA AIR MANAGER 4.0 master controller, all blower stations can be integrated seamlessly into Industrie 4.0 environments, thereby allowing continuous system optimisation through analysis of operating data and providing demand-oriented preventative maintenance and servicing (Predictive Maintenance) via remote diagnostics (Condition Monitoring).

# Intelligence inside: SIGMA CONTROL<sup>®</sup> 2 blower controller

Based on industrial PC technology, the SIGMA CONTROL 2 internal blower controller uses a range of sensors to monitor and control all relevant machine and process parameters for a reliable and economical operation. The availability of remote monitoring and control serves to optimise blower availability and efficiency even further.

A variety of communications modules enable blower systems equipped with SIGMA CONTROL 2 to connect to master control systems such as the SIGMA AIR MANAGER 4.0 and/or other centralised control systems via data bus.



## The control centre

The control unit features an easy-to-read display and durable input keys, whilst a clear menu structure with 30 selectable languages enables universal operation. A variety of operating modes are selectable on SFC/OFC machines.



## Stay connected

The Ethernet interface (10/100 Mbit/sec) allows users to call up operating parameters on any Internet browser via the integrated web server. Optional communication modules: Profibus DP, Modbus RTU and /TCP, Profinet IO and EtherNet/IP.

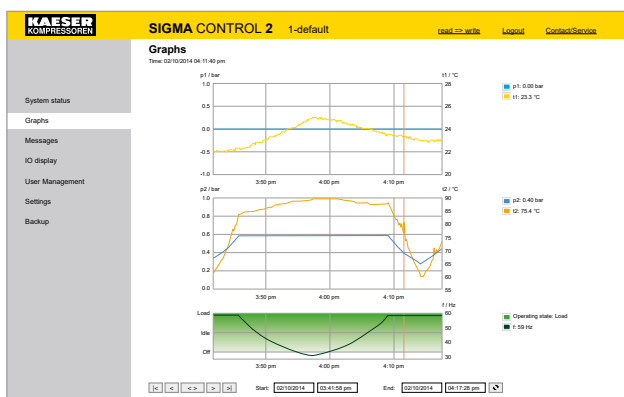

## KAESER CONNECT

Simply connect a PC and the SIGMA CONTROL 2 with the LAN, then enter the SC2 address and password in the browser. Now you can view machine status, operating data, warning messages and graphical representations of pressure, temperature and speed in real time.



## Updates and data storage

Software updates and operating parameters can quickly be uploaded and transferred via the convenient SD card slot, thereby keeping service costs to an absolute minimum. Key operating data can also be stored on the SD card.



### **BBC-HBC series**

Usable flow rate:  
0.59 to 93 m<sup>3</sup>/min

Differential pressure:  
- Gauge pressure up to 1000 mbar  
- Vacuum up to 500 mbar

OMEGA 



# Rotary lobe blower packages for integration into existing systems

Efficient, quiet, durable and versatile – whether used to convey bulk materials or as anti-heeling dampers on a container ship, KAESER blower packages are renowned worldwide for their dependable performance, no matter what the application may be. Small wonder, then, that they are so highly regarded by operators in every industry across the globe.



## IE3 energy-saving motors

All KAESER blower packages are equipped with dependable, Premium Efficiency IE3 drive motors (IP55 protection, Insulation Class F). Their exceptional efficiency boosts the energy performance of the whole system.



## Sensors

A wide range of sensors and switches for monitoring pressure, temperature, speed, oil level and filters ensures dependable operation of the blower, whilst allowing remote monitoring and visualisation of the operating status.

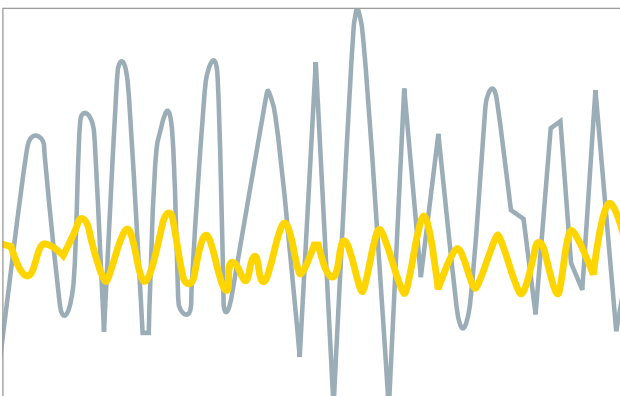

## Minimal pulsations and quiet operation

As pulsations from the conveying air can cause noise in the connected pipework in addition to noise from the machine itself, the targeted soundproofing measures on KAESER blowers are designed to minimise both types of sound emissions. Highly effective discharge silencers cover a wide frequency range so as to mitigate noise from pulsations in the conveying air.



## Automatic belt tensioning

The pivoting motor base with tensioning spring ensures precision belt tensioning irrespective of motor weight, thereby providing optimum levels of transmission efficiency at all times. Consequently, this system reduces both maintenance and energy costs.

# Premium blowers: HB-PI series – large and versatile

KAESER's HB-PI series rotary lobe blowers are the perfect choice for applications that require large air delivery volumes and maximum availability, such as in large water treatment plants or power stations.

Flexible, durable and dependable, in combination with the rapid-response KAESER Service they guarantee uninterrupted operation at all times.

## Technical specifications:

HB-PI series

Usable flow rate:  
55 to 160 m<sup>3</sup>/min

Pressure differential:  
- Gauge pressure up to 1000 mbar  
- Vacuum up to 500 mbar



## IE3 energy-saving motors

All KAESER blower packages are equipped with dependable, Premium Efficiency IE3 drive motors (IP55 protection, Insulation Class F). Medium-voltage motors can also be specified optionally.



## Flexible connection to external switching technology

HB-PI series packages are available prepared for connection to user-end switching technology on a project-specific basis, whether it be for operation at a fixed speed or via frequency converter. Medium-voltage versions are available upon request.



### Dependable belt drive

The pivoting motor base with tensioning spring ensures precision belt tensioning, thereby providing optimum levels of transmission efficiency at all times. This reduces wear whilst boosting reliability.



### Clever cooling air flow

Outstanding cooling performance is assured by the fact that the drive motor is equipped with a dedicated cooling air intake and ambient air from outside the sound enclosure is used as process air. This results in maximum efficiency, even under heavy load.



### Impeller

The impeller is constructed from a single piece of aircraft-grade aluminium. Its low mass enables swift acceleration and deceleration, resulting in highly dynamic control characteristics. This, in combination with a patented housing design, provides a broad control range at extremely high levels of efficiency.

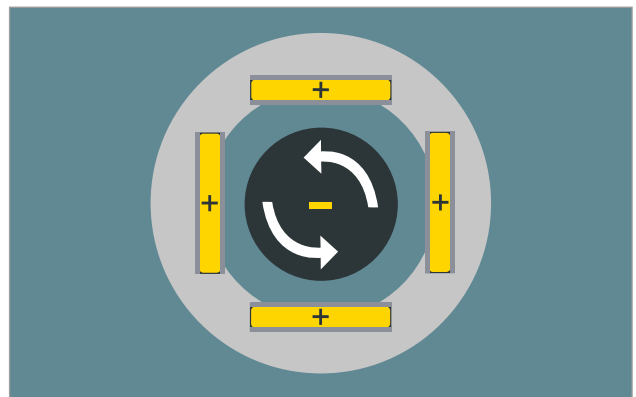

### Magnetic bearings

For best possible levels of unit availability, the magnetic bearings are oil-free and completely maintenance-free. The smart controller, with its integrated power failure protection system, recognises imbalances and sudden load shocks and compensates for them – rendering additional components such as buffer batteries and UPS devices unnecessary.

# Magnetic bearing turbo blowers – the undisputed masters of process air

Efficient, reliable and flexible – Pillaerator turbo blowers from KAESER are compact units developed specifically with aeration applications in mind. Equipped with contact-free magnetic bearings that require no lubrication, they guarantee a completely wear-free operation which renders oil and bearing changes unnecessary.

Turbo blowers are used wherever process air is required in the low pressure range – such as wastewater treatment, aerobic fermentation and flue gas desulphurisation applications.

## Technical specifications:

Flow rate: up to 267 m<sup>3</sup>/min

Pressure differential: 0.3 to 1.3 bar



## Canned motor

In a canned motor, rotor and stator are separated by a cylindrical tube. This allows an absolute hermetic sealing, which means that contaminants are reliably prevented from reaching the most sensitive parts of the machine.



## Cooling

Cooling takes place via an internal water circuit, so as to ensure operating conditions are consistently optimised. In addition to achieving constant temperatures for the motor and frequency converter, this allows the control cabinet to remain hermetically sealed. By conveying away all accumulated exhaust heat via the cooling water, expensive exhaust air ducting is rendered unnecessary.

# One-stop shop: Complete solutions from a renowned systems provider

An operation's blower air supply represents far more than the sum of the necessary equipment and components. By the same token, as a comprehensive compressed air and blower air systems provider, KAESER KOMPRESSOREN offers far more than just machines:

From detailed demand analysis to the seamless integration of a blower station into an existing operation and life-long availability assurance through the rapid-response KAESER AIR SERVICE.



## Precision demand analysis (ADA 2)

Once your exact blower air demand has been determined by means of KAESER's precision Air Demand Analysis (ADA), our experts use the KAESER Energy Saving System (KESS) to plan and design a solution that is specifically tailored to meet all your individual requirements, whilst providing the highest possible levels of efficiency and availability.



## Fast, worldwide service

Since even the highest quality machines require regular maintenance, KAESER AIR SERVICE, with its specially trained Service Technicians and advanced spare parts logistics, ensures continuous blower air availability across the globe.

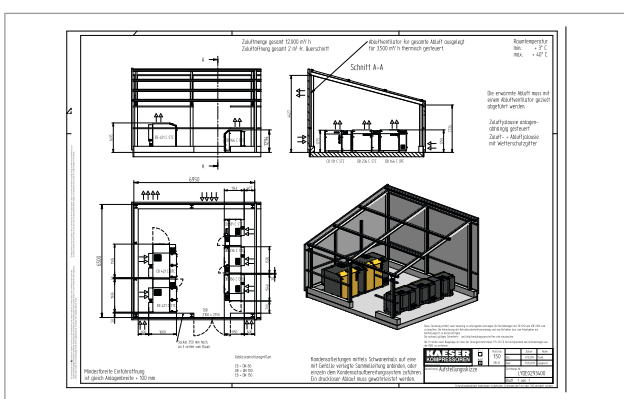

## Detailed and expert planning

KAESER's experts meticulously design every blower system to meet the specific needs of the customer. Needless to say, this includes planning the machine room ventilation and pipework, thereby ensuring peace of mind for users and project planners.



## Optimal climate control

KAESER's expertise and components in relation to climate control are also essential elements in a holistic approach to blower station design: The availability of cool intake air increases efficiency levels and therefore saves energy.

# KAESER blower accessories: For a wide range of applications

Different applications often require a very specific air quality. For example, some bulk materials are sensitive to heat, whilst others may clump together if humidity levels become too high. Another potential problem is contamination of the process air by particles contained within the ambient air.

For challenges such as these, KAESER is able to offer not only a wide range of cooler, dryer and filter models, but also the extensive experience of one of the world's leading systems providers, in order to ensure a perfect match of all air production and treatment components.

Furthermore, the SIGMA AIR MANAGER 4.0 enables the delivery volume of each blower station to be specifically tailored to meet actual air demand, thereby ensuring maximum energy efficiency.



## Coordination

Depending on the versions in question, the SIGMA AIR MANAGER 4.0 compressed air management system can coordinate operation of 4, 8 or 16 blowers within a blower station so as to ensure an even load distribution between the units and thereby maximise energy efficiency.



## Heat recovery

The heat exchanger can be integrated into the process lines to enable exceptional cooling of the process air, even at high ambient temperatures. The hot water produced in this way can be used for numerous heating purposes.





### Cooling

At an ambient temperature of +20 °C, the efficient ACA aftercooler is able to reduce the temperature of the compressed air to +30 °C without incurring any additional costs.



### Climate control

Carefully matched components, such as weather protection screens, fans, inlet/discharge silencers and suitable air ducting, help to ensure and maintain optimum climatic conditions in the machine room at all times.

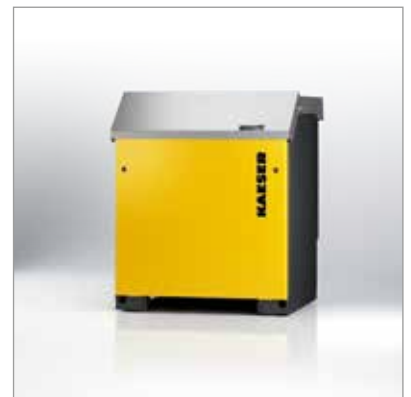

### Outdoor installation

At wastewater treatment plants, COMPACT blowers are often installed outdoors. Stainless steel rainproof covers and premium-quality, powder-coated enclosures ensure effective protection against the elements.



# Versions for specialist applications

Whether used on a silo vehicle as a mobile unloading station, for compression and/or for the conveying of media ranging from nitrogen to steam, KAESER blowers are ever-reliable and efficient OEM components.



## OMEGA B/PB – Corrosion resistant

Blowers are available with rotors and block housings cast from chromium-nickel alloy and with special internal block sealing for processes such as the mechanical compression of water vapour in vacuum distillation of aqueous media.



## WVC series – Fine vacuum

WVC series blocks with an intake capacity of up to 6,800 m<sup>3</sup>/h are ideal for fine-vacuum applications such as in pumping stations with a backing pump to boost their pumping speed.



## OMEGA PV – Rough vacuum

With an intake capacity of up to 120 m<sup>3</sup>/min for low-vacuum applications and a maximum of 900 mbar differential pressure, the OMEGA PV blower block is exceptionally robust and, with its ability to alternate between gauge pressure and vacuum by selective switching of the process lines, is perfectly suited for use with silo vehicles. Block cooling is provided by ambient air via pre-inlet ducts.



## OMEGA PN: Nitrogen conveying

For pneumatic conveying of bulk materials in a nitrogen atmosphere, leakages of any kind – including from the rotary lobe blower – must be kept to an absolute minimum. PN series blocks are available with a wear-free sliding ring seal on the drive shaft rotary transmission lead-through. Complete packages with OMEGA PN blocks are also available for nitrogen conveying applications.



### **Rotor and block machining**

All rotors and blocks are precision machined to micron accuracy, so that the resulting surface quality renders wear-prone sealing coatings unnecessary.



### **Measurement and inspection**

In order to maintain consistent product quality, we meticulously inspect every single block housing and rotor using precision measuring equipment, so as to ensure that it is manufactured to within permissible tolerances.



### **Powder coating**

The housings receive their high-quality scratch and corrosion-resistant surface finish in an environmentally friendly, 180 °C powder-coating process.



# Advanced manufacture: Quality and performance

A high level of vertical integration guarantees consistently high quality of both mechanical and electrical components and ensures seamless interplay between each individual part. All components are precisely matched to one another and meticulously documented.

This enables traceability and guarantees a trouble-free supply of spare parts at all times.



## Block manufacture

As with the rotors, the housing for every single KAESER rotary lobe blower block is manufactured in an advanced, climate-controlled CNC machining centre to ensure consistently high product quality.



## Final inspection

All necessary adjustments, such as belt tensioning and alignment, are carried out ex-works prior to delivery. Moreover, every blower block is delivered ready-filled with oil and with all valves adjusted. All data are documented.



## Flexible production

The very latest production techniques and processes at KAESER's Gera plant ensure exceptional product quality and enable customer-specific requirements to be met with minimal lead time.

# Technical specifications

Rotary screw blowers (EBS to HBS series, STC/SFC) – up to 250 kW, connection-ready with integrated electronics

Model	Gauge pressure			Vacuum			Pipe connection	Dimensions With control cabinet and sound enclosure W x D x H mm	Max. mass kg		
	Max. pressure differential mbar	Max. flow rate <sup>*)</sup> m <sup>3</sup> /min	Max. rated motor power kW	Max. pressure differential mbar	Max. flow rate <sup>*)</sup> m <sup>3</sup> /min	Max. rated motor power kW					
CBS 121 L SFC	700	12.6	18.5	-	-	-	80	1110 x 1370 x 1670	730		
CBS 121 L STC		10.3							720		
CBS 121 M SFC	1100	12.5	22	550	10	11			750		
CBS 121 M STC		10.2		-	-	-			740		
DBS 221 L SFC	700	23	30	-	-	-	100	1110 x 1480 x 1670	820		
DBS 221 L STC		19	22						800		
DBS 221 M SFC	1100	22	37	550	22	30			850		
DBS 221 M STC		18		-	-	-					
EBS 410 CL SFC	700	41	37	-	-	-	150	1280 x 1760 x 1820	1400		
EBS 410 CL STC		34									
EBS 410 CM SFC	1000	30	37	550	41	37					
EBS 410 CM STC				-	-	-					
EBS 410 L SFC	700	41	55	-	-	-				1460 x 1760 x 1970	1520
EBS 410 L STC											
EBS 410 M SFC	1100	40	75	-	-	-					
EBS 410 M STC											
FBS 660 L SFC	650	67	75	-	-	-	200	2250 x 1950 x 1900	1850		
FBS 660 L STC											
FBS 660 M SFC	1100	66	110	550	63	75			2200		
FBS 660 M STC				-	-	-					
HBS 1600 L SFC	650	160	200	-	-	-	300	2065 x 3715 x 2225	5900		
HBS 1600 M SFC	1100		250						6000		

\*) Performance specifications as per ISO 1217 Annexe C for STC version, Annexe E for SFC version

## Turbo blowers – 150 kW and 300 kW

Model	Pressure differential range mbar	Flow rate range <sup>*)</sup>		Drive motor rated power kW	Maximum sound pressure level <sup>**)</sup> dB(A)	Pipe connection <sup>***)</sup> DN	Dimensions W x D x H mm	Mass kg
		m <sup>3</sup> /min	m <sup>3</sup> /h					
HP 4000	400 – 1300	16 – 83	950 – 5000	150	74	200	1800 x 1525 x 2125	1815
MP 6000	300 – 1100	25 – 108	1500 – 6500		75			
LP 8000	300 – 900	25 – 133	1500 – 8000		76			
HP 9000	400 – 1300	42 – 183	2500 – 11,000	300	75	400	2930 x 2125 x 2155	3785
MP 12000	300 – 1100	50 – 233	3000 – 14,000					
LP 14000	300 – 900	75 – 267	4500 – 16,000					

\*) Flow rate, complete system as per ISO 5389:2005: absolute inlet pressure 1 bar(a), cooling and air inlet temperature +20 °C

\*\*) Sound pressure level as per ISO 2151 and basic standard ISO 9614-2, tolerance: ± 3 dB (A) – dependent upon operating point

\*\*\*) Compressed air connection (with add-on diffuser)

## Compact blowers (BBC to FBC series, STC/OFC) – up to 132 kW, connection-ready with integrated electronics

Model	Gauge pressure		Vacuum		Max. rated motor power kW	Pipe connection DN	Dimensions With control cabinet and sound enclosure W x D x H mm	Max. mass kg
	Max. pressure differential	Max. flow rate <sup>*)</sup>	Max. pressure differential	Max. flow rate <sup>*)</sup>				
	mbar	m³/min	mbar	m³/min				
BB 69 C	1000	5.9	500	5.9	15	65	1210 x 960 x 1200	455
BB 89 C		8.2		5.9	15			461
CB 111 C	800	8.8	400	8.9	18.5	80	1530 x 1150 x 1290	583
CB 131 C	1000	12.3	500	12.4	30			642
DB 166 C	1000	15.6	500	15.7	37	100	1530 x 1150 x 1290	802
DB 236 C		22.1		22.3	45			822
EB 291 C	1000	28.6	500	28.8	75	150	1935 x 1600 x 1700	1561
EB 421 C		40.1		40.4	75			1606
FB 441 C	1000	41.3	500	41.6	90	200	2230 x 1920 x 1910	2326
FB 621 C		58.5		58.9	132			2839
FB 791 C	800	71.3		71.8	110	250	2230 x 1920 x 2090	2541

<sup>\*)</sup> Performance specifications as per ISO 1217 Annexe C for STC version, Annexe E for OFC version

## Blower packages (BBC to HBPI series) – up to 250 kW

Model	Gauge pressure		Vacuum		Max. rated motor power kW	Pipe connection DN	Dimensions Without sound enclosure W x D x H mm	Max. mass kg	Dimensions With sound enclosure W x D x H mm	Max. mass kg
	Max. pressure differential	Max. flow rate <sup>*)</sup>	Max. pressure differential	Max. flow rate <sup>*)</sup>						
	mbar	m³/min	mbar	m³/min						
BB 52 C	1000	4.7	500	4.7	7.5	50	785 x 635 x 940	140	800 x 790 x 1120	210
BB 69 C		5.9		5.9	11	65	800 x 660 x 960	195		325
BB 89 C		8.2		8.3	15		890 x 660 x 960	201		331
CB 111 C	800	8.8	400	8.9	18	80	855 x 1010 x 1290	263	990 x 1160 x 1290	443
CB 131 C	1000	12.3	500	12.4	30			302		482
DB 166 C	1000	15.6	500	15.7	37	100	990 x 1070 x 1120	432	1110 x 1160 x 1290	632
DB 236 C		21.1		22.3	45			482		682
EB 291 C	1000	28.6	500	28.8	75	150	1240 x 1370 x 1510	921	1420 x 1600 x 1659	1261
EB 421 C		40.1		40.4	75			966		1306
FB 441 C	1000	41.3	500	41.6	90	200	1790 x 1450 x 1750	1450	1920 x 1620 x 1910	1960
FB 621 C		58.5		58.9	132			1865		2375
FB 791 C	800	71.3	450	71.8	110	250	1870 x 1450 x 1900	1717		2247
HB 950 C	1000	93.1	500	91.65	200	250	1700 x 1700 x 1950	3005	2170 x 1864 x 2110	3805
HB 1300 PI		125		122.93	250	300	2710 x 1600 x 2350	3465	3205 x 2150 x 2610	4285
HB 1600 PI	800	156	450	153.27						3625

<sup>\*)</sup> Performance specifications as per ISO 1217 Annexe C

# The world is our home

As one of the world's largest manufacturers of compressors, blowers and compressed air systems, KAESER KOMPRESSOREN is represented throughout the world by a comprehensive network of branches, subsidiaries and authorised distribution partners in over 140 countries.

By offering innovative, efficient and reliable products and services, KAESER KOMPRESSOREN's experienced consultants and engineers work in close partnership with customers to enhance their competitive edge and to develop progressive system concepts that continuously push the boundaries of performance and technology. Moreover, decades of knowledge and expertise from this industry-leading systems provider are made available to each and every customer via the KAESER group's advanced global IT network.

These advantages, coupled with KAESER's worldwide service organisation, ensure that every product operates at peak performance at all times, whilst providing maximum availability.



## **KAESER COMPRESSORS Australia Pty. Ltd.**

Locked Bag 1406 – Dandenong South – Vic. 3164  
45 Zenith Road – Dandenong – Vic. 3175  
Phone: +61 39791 5999 – Fax: +61 39791 5733  
www.kaeser.com – E-mail: info.australia@kaeser.com

## **KAESER COMPRESSORS NZ Limited**

PO BOX 301261 – Albany – Auckland 0752  
18B Tarnedale Grove – Albany – Auckland 0632  
Phone +64 9 941 0499  
www.kaeser.com – E-mail: info.newzealand@kaeser.com